

Model BASE / BASE +

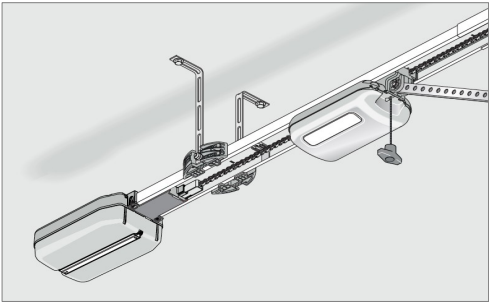

### 10.5 Programming the transmitter

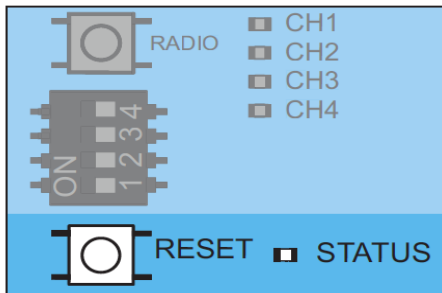

Fig. 1

**i** **INFORMATION**

- If no transmission command is received within 30 seconds of pressing the Radio button, the radio receiver switches to normal mode.

1. Press the Radio button repeatedly to select the required radio channel.

	1 x	2 x	3 x	4 x
<b>LED</b>				
CH 1				
CH 2				
CH 3				
CH 4				

2. Press the desired button on the transmitter until the previously selected LED (CH 1, CH 2, CH 3, CH 4) goes out.
  - ⇒ **LED goes out - programming is complete.**
  - ⇒ The transmitter has transferred the radio code to the radio receiver.
3. Repeat the above steps to program additional transmitters.

**If the memory capacity has been reached**

All 40 transmitter commands are available for all channels. If an attempt is made to program additional transmitters, the red LEDs of radio channels CH 1 - CH 4 flash. If more memory spaces is needed, see Chapter "10.6 Information on Memo".